

Bearings and their lubrication

This primer will help you understand the basics—and prepare for the CLS exam.



KEY CONCEPTS

- Plant managers often blame a bearing failure on its manufacturer or the oil supplier without understanding how these components work.
- The correct bearing must be selected for the application, properly installed, maintained and lubricated.
- Bearing types include plain, rolling-element, magnetic, jewel and air.

SOME TIME AGO I WROTE ABOUT HOW PEOPLE should work through the process of how bearings are used in their plants before blaming the bearing manufacturer or lubricant supplier for a failure. This is both a simple and yet difficult subject for the average person responsible for equipment that has bearings. (**Editor's Note:** Bob's article, "When Bad Things Happen to Good Bearings," is available in the October 2005 issue and also at www.stle.org).

Key points of the article were to first ascertain such things as:

- Was the right bearing installed (size, type, etc.)?
- Was the installation correctly carried out (seated properly, alignment checked, etc.)?
- Was the bearing correctly lubricated with the right lubricant and did the lubricant meet proper specifications for the service?
- Were the seals the right type, properly installed and adjusted?
- Was the equipment operated within design limits?
- Was there any chance for contamination during any of the above?

Plain bearings are compact, lightweight and have a high load-carrying capacity.

There are also more obscure failure modes such as pitting due to electrical arcing across the bearing or false brinnelling when shipping cars or machinery long distances and the machine bounces or rocks back and forth on the bearings. Perhaps you can think of other examples, but the point is this: It is not until these kinds of questions are answered that we can start to become suspicious of the equipment manufacturer, bearing manufacturer or lubricant manufacturer.

In the previous article, in the interests of brevity, I did not cover the basic types of bearings we most commonly encounter. Unless we are designing the equipment or work for a bearing company, a basic knowledge should be enough. When you purchase the equipment, the manufacturer and bearing company will have figured out the proper type of bearings. Assuming you use the equipment as intended, everything should work out. They also should recommend a maintenance cycle and procedure; again things should work out if you use the equipment as intended.

BEARING BASICS

So we can all catch up, the purpose of this article is to review the basic types of bearings, both plain and rolling element.

A plain bearing, also known as a plane bearing or a friction bearing, is the simplest type of bearing, comprising just a bearing surface. A simple linear bearing can be a pair of flat surfaces designed to move—for example, a desk drawer and the slides it rests on. In a shaft application, the journal (the part of the shaft in contact with the bearing) slides over the bearing surface either axially or radially, or I suppose both.

Plain bearings are the least expensive type of bearing. They are also compact, lightweight and have a high load-carrying capacity. Lubrication is generally provided by grooving that supplies and distributes the grease or oil (grooves are placed out of the load zone). The correct oil film thickness is determined by viscosity, surface roughness, speed, load and clearances for the specific application.

When up to speed, the lubrication regime is hydrodynamic. Thus, theoretically the bearing can last forever, as shown in Figure 1, where the journal runs on a full film of oil with no real wear.

Figure 1

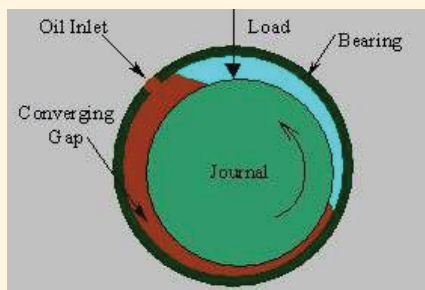

Examples of such bearings include:

Plain Journal Bearings

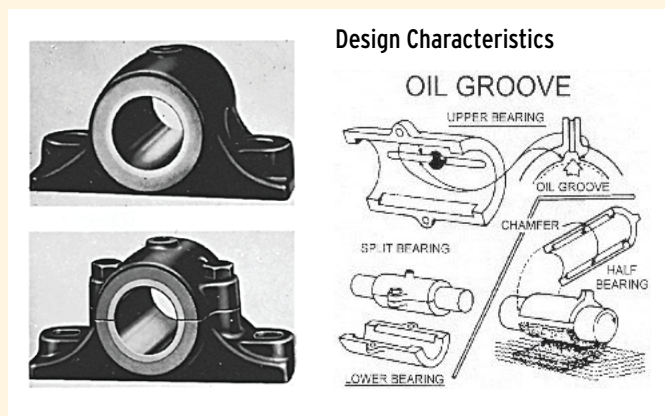

Plain Sleeve Bearings



In addition to these designs, there are also plain spherical bearings and plain angular contact bearings.

Plain Spherical Bearings

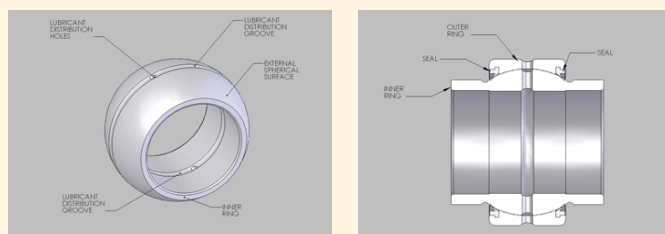

Best suited for applications requiring loads under oscillatory and/or continuous rotational motions. They are also intended for applications with angular misalignment.

Plain Angular Contact Bearings

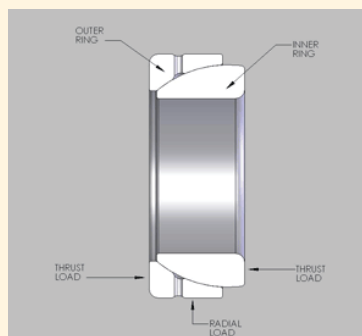

Best suited for applications with heavy loads, single direction, thrust load. If thrust load reverses, an angular contact bearing will separate. For applications requiring reversing thrust load, use a pair of angular contact bearings.

Angular ball bearings are designed to handle both radial and light axial loads.

The next major class of bearings is rolling element bearings, which the ball bearing is one of the most common. Ball bearings tend to have lower load capacity for their size than other kinds of rolling element bearings due to the smaller contact area between the balls and races. They can tolerate some minor misalignment of the inner and outer races.

Figure 2

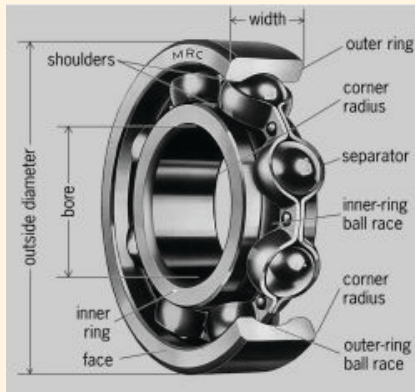

Of the various ball bearing types, one is the so-called deep groove ball bearing (see Figure 2).

In a deep-groove radial bearing, the race dimensions are close to the dimensions of the balls that run in it. Deep groove bearings can support higher loads because of more area of surface contact.

Angular ball bearings are designed to handle both radial and light axial loads.

Similarly, for applications where axial loads are part of the design as well as radial loads, there are axial ball bearings, which are a more extreme version of angular ball bearings.

For those applications where the shaft may stress the bearing by not staying perfectly aligned, there are self-aligning ball bearings.

Self-Aligning Ball Bearings

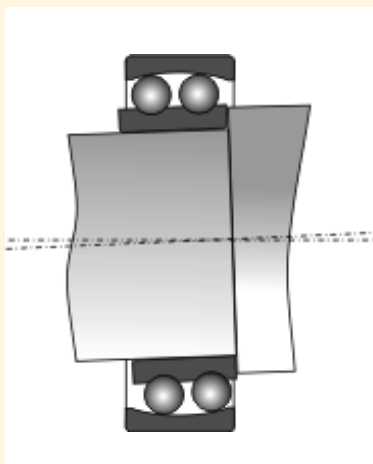

For those applications where the load is purely axial, there are thrust ball bearings:

Thrust Ball Bearings



The next major class of rolling element bearings is the roller bearings. These are designed for higher loads and handle similar design problems as ball bearings. First of these is the tapered roller bearing where the key element in the design comes from the fact that cones (see Figure 3) can roll over each other without slipping.

Figure 3

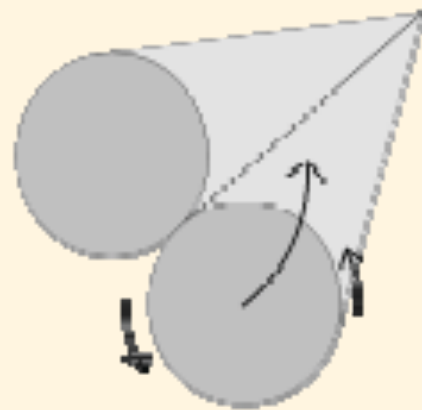

Again, when some flex is experienced or angular error in alignment can be expected, there are spherical roller bearings. For high radial load applications, there are cylindrical roller bearings. And for high-load thrust bearing applications, there are thrust tapered roller bearings. These bearings enable axially very compact bearing arrangements. They can carry very heavy axial loads, are insensitive to shock loads and are stiff. They are available in single-direction tapered roller thrust bearings and double-direction tapered roller thrust bearings.

Likewise for high thrust loads, there are cylindrical roller thrust bearings. Cylindrical roller thrust bearings are suitable for heavy axial loads. They are relatively insensitive to shock loads, are very stiff and require little axial space. Further, they are usually available as single-direction bearings, which can only accommodate axial loads acting in one direction.

Cylindrical roller thrust bearings are suitable for heavy axial loads.

One of the most versatile designs is the spherical roller thrust bearing. Here, the load is transmitted from one raceway to the other at an angle to the bearing axis. Thus, they can accommodate radial loads in addition to simultaneously acting axial loads. Their self-aligning feature makes them relatively insensitive to shaft deflection and misalignment. They can, therefore, support very heavy axial loads and relatively high-speed operation.

A special case of rolling element bearings are needle bearings. Needle bearings have a large surface area in contact with the bearing outer surfaces compared to ball bearings. They are compact—less added clearance (difference between the diameter of the shaft and the outer diameter of the bearing). Thus they can handle extremely high radial load-carrying capacity.

Some specialty types of bearings include magnetic bearings, which suspend the shaft by electromagnets surrounding the shaft. Thus in operation, it exhibits no wear and, of course, very low friction. Obviously these are very expensive bearings to purchase and operate.

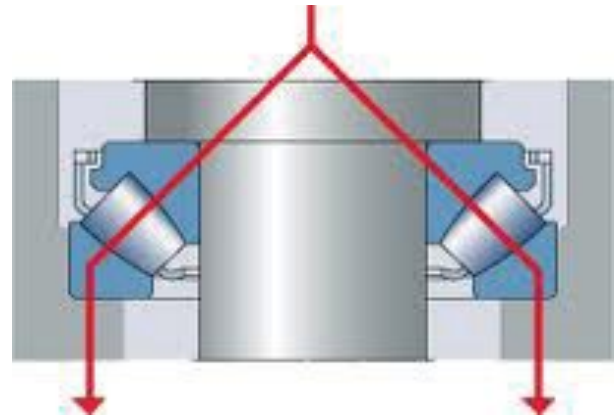

Spherical Roller Thrust Bearings

Performance and service that are
LEADING EDGE
People and specialty products
you can count on.

- SpectraSyn Elite™ mPAO Polyalphaolefin Base Oils Group IV
- SpectraSyn Plus™ Base Oils Group IV
- SpectraSyn™ Polyalphaolefin Base Oils Group IV
- EstereX™ Esters Group V

- Synesstic™ Alkylated Naphthalene Group V
- Ultra-S™ Base Oils Group III
- Pure Performance® Base Oils Group II
- ConoPure® Process Oils



Global Sales and Service

7010 Mykawa | Houston, Texas 77033 | 800.228.3848 | www.jamdistributing.com

EstereX, SpectraSyn, SpectraSyn Ultra and Synesstic are trademarks of Exxon Mobil Corporation. Ultra-S is a trademark and Pure Performance and ConoPure are registered by ConocoPhillips Company.

J.A.M.
SPECIALTY PRODUCTS

Jewel bearings are yet another unusual type but which are commonly used in clocks, watches and other fine mechanisms. They can be extremely small and often are not lubricated.

Finally, air bearings are yet another specialty bearing, which overcomes the disadvantages of oil or grease lubrication systems in equipment such as turbochargers. Here oil can enter the intake air and have a negative im-

act on exhaust emissions in the turbocharger. Also, oil supplied to a roller bearing creates some level of hydrodynamic drag. That is eliminated in an air bearing. Oil will coke if the engine is turned off when the turbo is still very hot.

Further, an oil-lubricated turbocharger would need to be designed to supply oil and with drain hoses and perhaps a cooler, all of which increases

Needle Bearings



Jewel Bearings in a watch



cost and complexity of the turbo. Use of plain and rolling element bearings would need a relatively large blade tip clearance, whereas air bearings have a very low profile.

Well, that is probably more than you ever wanted to know about bearing designs. Yet, for those preparing for the CLS certification examination, you will need to have an awareness of the different kinds of bearings and how to troubleshoot them. **TLT**



Bob Gresham is STLE's director of professional development. You can reach him at rgresham@stle.org.

www.nceed.com

1-888-726-3114

More to Offer...



A Partnership that benefits you.

NCEED is now a division of ChemCeed, and that means that you will receive the same personal service but with increased capabilities. NCEED is proud to offer an expanded product line, multiple stocking points to ensure strong availability of products, repackaging services, an improved sourcing network, and much more!



NCeed enterprises
info@nceed.com